

# ST GC05

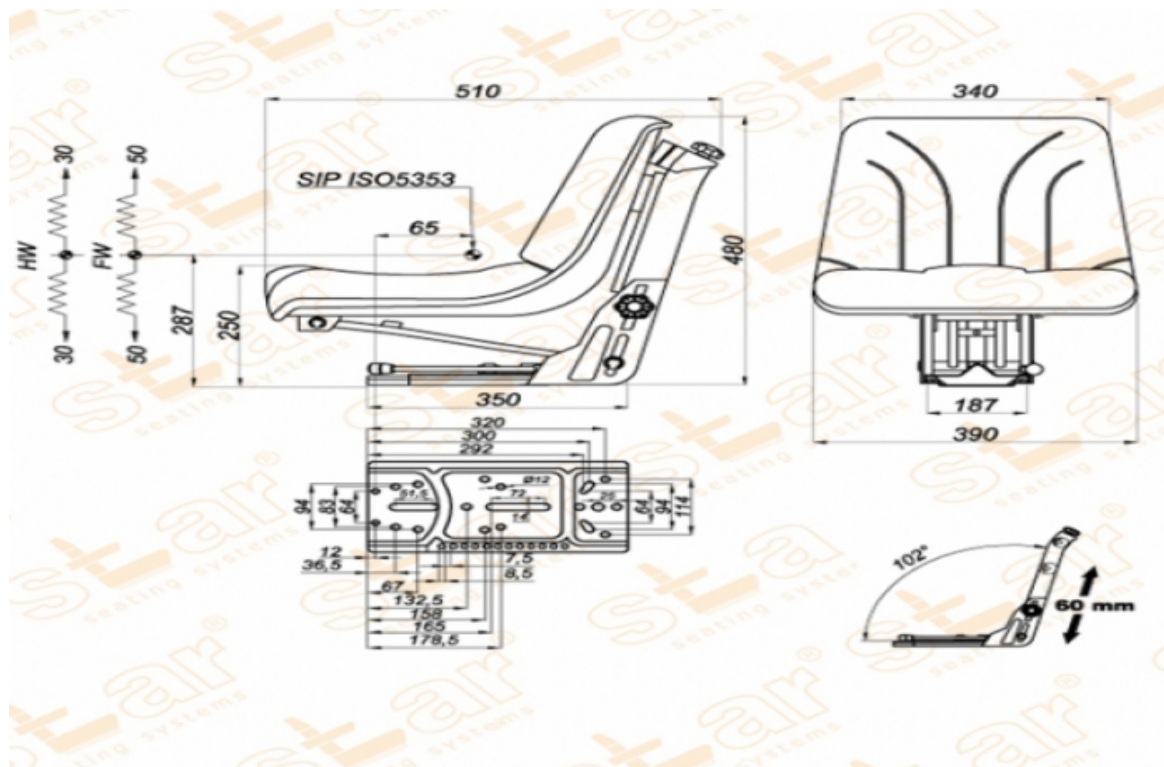

BRAND: STAR

CAPACITY:

## Seat Features

- Suspension** : Mechanical Suspension
- Sliding Base** : Fore and Aft. Adjustment 150mm
- Suspension Stroke** : 80-100mm (Couple Spring & Hydraulic Shock Absorber)
- Height Adjustment** : 60mm
- Weight Adjustment** : 50-120kg.
- Backrest Adjustment** : No
- Angles Adj.** : No
- Lumbar Adjustment** : No
- Certificates** : **Classes I,II (e1\*78/764) - (76/115/EEC)**

## Description

With water hole - Overturnable Pan Type Seat - With water hole - Overturnable Small Pan Type Seat - Forklift or Garden Tractor or Equipment Seats

## Options

- SB010 Static Seat Belt** :
- SB020 Two Point Automatic Seat Belt** :