

STplus TV3-LXJ

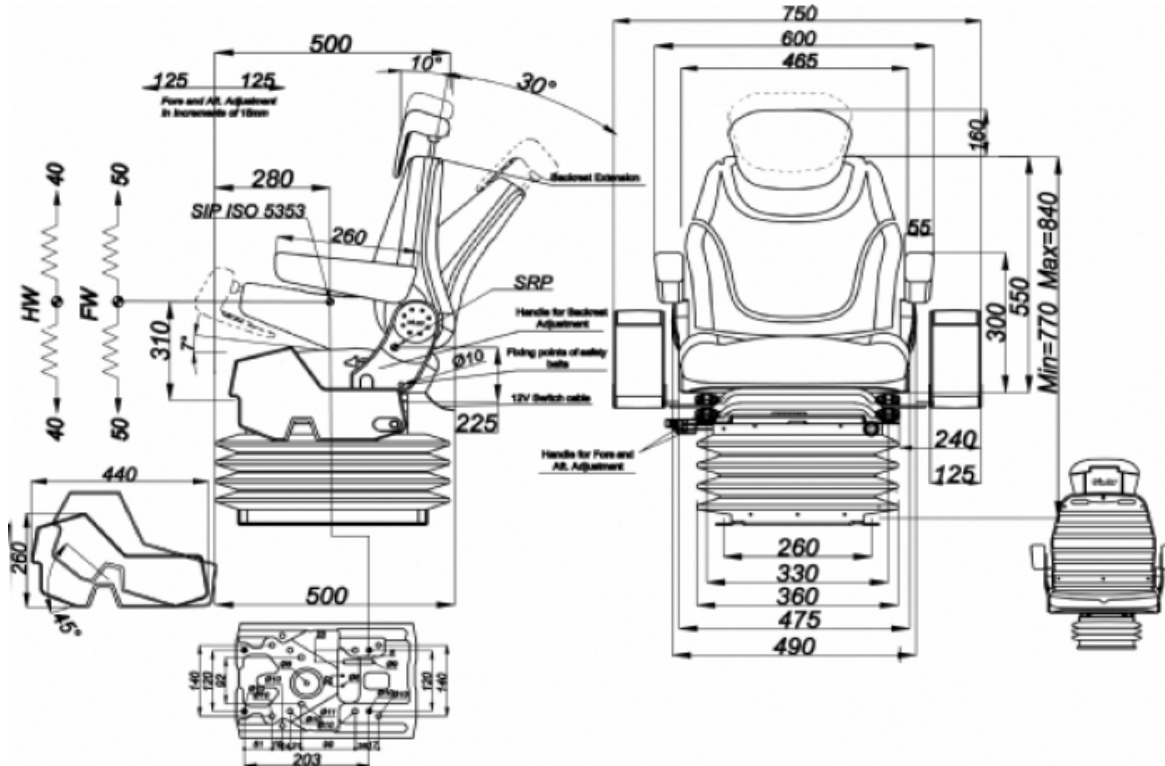

BRAND: STAR

CAPACITY:

Seat Features

- Suspension** : AIR Suspension
- Sliding Base** : Fore and Aft. Adjustment 190mm + 190mm (With Couple Locked)(Incremente of 15mm)
- Suspension Stroke** : 140mm (Air Suspension & Hydraulic Shock Absorber)
- Height Adjustment** : Automatic
- Weight Adjustment** : 50-130kg.
- Backrest Adjustment** : 30°-85°
- Angles Adj.** : No
- Lumbar Adjustment** : Mechanical
- Certificates** : **Classes I,II (e24*78/764) - (76/115/EEC)**

Description

12V/24V Air Compressor 9 A - Fore & Aft isolator with damper-35mm travel - Adjustable joystick box with gas spring for left side - Construction Vehicle Seats

Options

- SB010 Static Seat Belt** :
- SB020 Two Point Automatic Seat Belt** :
- SP02 Foldable Armrest** :
- SP02ARN Adjustable Foldable Armrest** :
- 12V & 24V Operator Switch** :
- SP01AH Headrest** :
- DB01 Document Belt** :
- 12V & 24V Air Compressor** :

LTT 18 360 Large Swivel Mechanism

: 

12V & 24V 3 Adj. Heater

: 